



HADEN

ESTD. ENGLAND 1958



INSTRUCTION MANUAL

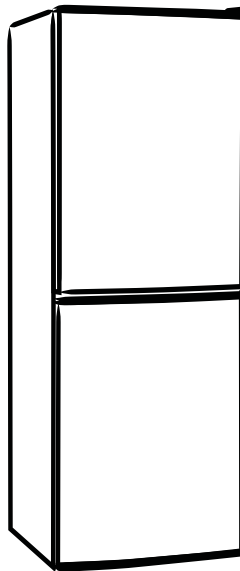

MODEL NUMBER: HK124W

To request a service call tel. 01759 487830
Or visit www.appliancesupport.co.uk

Dear user

THANK YOU and **CONGRATULATIONS** on your purchase of this high-quality Haden product. Your Haden refrigerator is designed for reliable, trouble-free performance.

For future reference, please record your product model and serial number on the back of the product or above the compressor compartment on the right.

Model Number _____

Serial Number _____

1.SAFETY INFORMATION	3
2.PROPER USE OF REFRIGERATOR	11
2.1 Placement	11
2.2 Energy saving tips	12
2.3 Changing the Light	12
2.4 Start to use.....	12
2.5 Names of components.....	13
2.6 Functions	14
2.7 Leveling door.....	15
2.8 Leveling feet	16
3.MAINTENANCE OF REFRIGERATOR	17
3.1 Overall cleaning.....	17
3.2 Defrosting	18
3.3 Out of operation.....	18
3.4 Cleaning the glass shelf.....	18
4.TROUBLE SHOOTING	19
5.APPENDIX	20

1. SAFETY INFORMATION

YOUR SAFETY AND THE SAFETY OF OTHERS ARE VERY IMPORTANT

To prevent injury to the user or other people and property damage, the instructions shown here must be followed. Incorrect operation due to ignoring of instructions may cause harm or damage, including death.

The level of risk is shown by the following indications.



Prohibition symbol

This is a prohibition symbol.

Any non-compliance with instructions marked with this symbol may result in damage to the product or endanger the personal safety of the user.



Warning symbol

This is a warning symbol.

It is required to operate in strict observance of instructions marked with this symbol; or otherwise damage to the product or personal injury may be caused.



Cautioning symbol

This is a cautioning symbol.

Instructions marked with this symbol require special caution. Insufficient caution may result in slight or moderate injury, or damage to the product.

IMPORTANT SAFETY INSTRUCTIONS



Risk Of Fire / Flammable Materials



WARNING

- This appliance is intended to be used in household and similar applications such as staff kitchen areas in shops, offices and other working environments; farm houses and by clients in hotels, motels and other residential type environments; bed and breakfast type environments; catering and similar non-retail applications.
- This appliance is not intended for use by persons (including children) with reduced physical, sensory or mental capabilities, or lack of experience and knowledge, unless they have been given supervision or instruction concerning use of the appliance by a person responsible for their safety.

- Children should be supervised to ensure that they do not play with the appliance.
- If the supply cord is damaged, it must be replaced by the manufacturer, its service agent or similarly qualified persons in order to avoid a hazard.
- Do not store explosive substances such as aerosol cans with a flammable propellant in this appliance.
- The appliance has to be unplugged after use and before carrying out user maintenance on the appliance.
- **WARNING:** Keep ventilation openings, in the appliance enclosure or in the built-in structure, clear of obstruction.
- **WARNING:** Do not use mechanical devices or other means to accelerate the defrosting process, other than those recommended by the manufacturer.
- **WARNING:** Do not damage the refrigerant circuit.
- **WARNING:** Do not use electrical appliances inside the food storage compartments of the appliance, unless they are of the type recommended by the manufacturer.
- **WARNING:** Please abandon the refrigerator according to local regulators for its use flammable blowing gas and refrigerant.
- **WARNING:** When positioning the appliance, ensure the supply cord is not trapped or damaged.
- **WARNING:** Do not locate multiple portable socket-outlets or portable power supplies at the rear of the appliance.
- Do not use extension cords or ungrounded two prong adapters.
- **WARNING:** Connect to potable water supply only. (suitable for ice cube maker)







DANGER

- Risk of child entrapment. Before you throw away your old refrigerator or freezer:
 - Take off the doors.
 - Leave the shelves in place so that children may not easily climb inside.
- The refrigerator must be disconnected from the source of electrical supply before attempting the installation of accessory.
- Refrigerant and cyclopentane foaming material used for the appliance are flammable. Therefore, when the appliance is scrapped, it shall be kept away from any fire source and be recovered by a special recovering company with corresponding qualification other than be disposed by combustion, so as to prevent damage to the environment or any other harm.



WARNING

For EU standard:

- This appliance can be used by children aged from 8 years and above and persons with reduce physical sensory or mental capabilities or lack of experience and knowledge if they have been given supervision or instruction concerning use of the appliance in a safe way and understand the hazards involved. Children shall not play with the appliance. Cleaning and user maintenance shall not be made by children without supervision. Children aged from 3 to 8 years are allowed to load and unload refrigerating appliances.
- To avoid contamination of food, please respect the following instructions:
 - Opening the door for long periods can cause a significant increase of the temperature in the compartments of the appliance.
 - Clean regularly surfaces that can come in contact with food and accessible drainage systems.
 - Clean water tanks if they have not been used for 48h; flush the water system connected to a water supply if water has not been drawn for 5 days. (Note 1)
 - Store raw meat and fish in suitable containers in the refrigerator, so that it is not in contact with or drip onto other food.
 - Two-star  frozen-food compartments are suitable for storing pre-frozen food, storing or making ice-cream and making ice cubes. (Note 2)
 - One- , two-  and three-star  compartments are not suitable for the freezing of fresh food. (note 3)
 - For appliances without a 4-star  compartment: this refrigerating appliance is not suitable for freezing foodstuffs. (note 4)
 - If the refrigerating appliance is left empty for long periods, switch off, defrost, clean, dry, and leave the door open to prevent mould developing within the appliance.
- Note 1,2,3,4: Please confirm whether it is applicable according to your product compartment type.
- For a freestanding appliance: this refrigerating appliance is not intended to be used as a built-in appliance.

SAVE THESE INSTRUCTIONS

THIS APPLIANCE IS FOR HOUSEHOLD USE ONLY

State of California Proposition 65 Warnings:

 **WARNING:** Cancer and Reproductive Harm
-www.P65Warnings.ca.gov.

PROPER DISPOSAL

WARNING

Suffocation Hazard

Before you throw away your old freezer or refrigerator:

- Remove the door or lid so that children cannot hide or get trapped inside your old appliance.
- Leave any shelves in place so that children may not easily climb inside.
- Failure to follow these instructions can result in death or brain damage.

IMPORTANT:

Flammable gas and refrigerant used. It is the consumer's responsibility to comply with Federal and Local regulations when disposing of this product. Refrigerants must be evacuated by a licensed, EPA certified refrigerant technician in accordance with established procedures.

ELECTRICITY RELATED WARNINGS

- Do not pull the power cord when pulling the power plug of the refrigerator. Please firmly grasp the plug and pull out from the socket.
- To ensure safe use, do not damage the power cord or use the power cord when it is damaged or worn.
- Please use a dedicated power socket; the power socket shall not be shared with other electrical appliances.

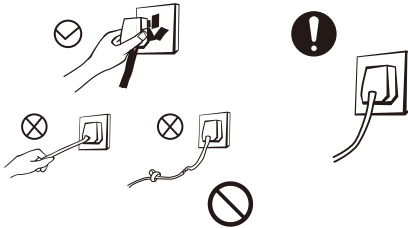

- The power cord should be firmly contacted with the socket, otherwise fire may be caused.
- Please ensure that the grounding electrode of the power socket is equipped with a reliable grounding line .
- Please turn off the valve of leaking gas and then open doors and windows in case of leakage of gas and other flammable substances. Do not unplug the refrigerator and other electrical appliances considering that spark may cause a fire.

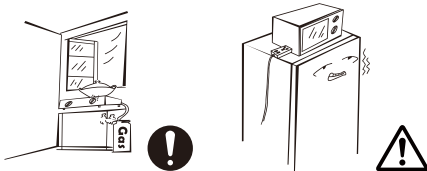

- Do not use electrical appliances on top of the appliance, unless they are of the type recommended by the manufacturer.

WARNINGS RELATED TO PLACING ITEMS

- Do not place flammable, explosive, volatile and highly corrosive items in the refrigerator to prevent damages to the product or fire accidents.
- Do not place flammable items near the refrigerator to avoid fires.

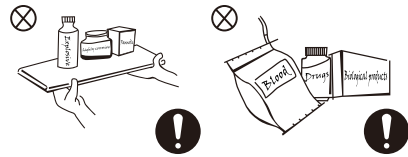

- This product is a household refrigerator and is only suitable for the storage of foods. According to national standards, a household refrigerator shall not be used for other purposes, such as storage of blood, drugs or biological products.
- Do not store beer, beverages or other fluids contained in bottles or enclosed containers in the freezing chamber of the refrigerator, otherwise the bottles or enclosed containers may crack due to freezing and cause damages.



WARNINGS FOR USE

- Do not arbitrarily disassemble or reconstruct the refrigerator, nor damage the refrigerant circuit; maintenance of the appliance must be conducted by a specialist.
- A damaged power cord must be replaced by the manufacturer, its maintenance department or related professionals in order to avoid danger.

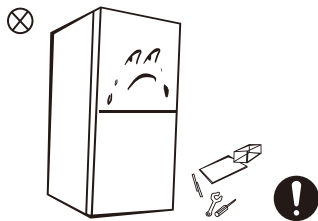

- The gaps between refrigerator doors and between doors and refrigerator body are small, do not place your hands in these areas to prevent squeezing your fingers. Please be gentle when opening the refrigerator door to avoid articles falling out.
- Do not pick up food or containers with wet hands in the freezing chamber when the refrigerator is running, especially metal containers in order to avoid frostbite.

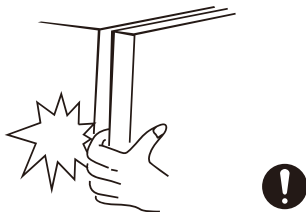

- Do not allow children to enter or climb inside the refrigerator to prevent that children are sealed in the refrigerator or injured by the falling refrigerator.
- Do not spray or wash the refrigerator; do not place the refrigerator in moist places easy to be splashed with water so as not to affect the electrical insulation properties of the refrigerator.



- Do not place heavy objects on top of the refrigerator considering that objects may fall when opening the door, and accidental injuries might be caused.
- Please pull out the plug in case of power failure or cleaning. Do not connect the refrigerator to power supply within five minutes to prevent damages to the compressor due to successive starts.



ENERGY WARNINGS

- 1.** Refrigerating appliances might not operate consistently (possibility of defrosting of contents or temperature becoming too warm in the frozen food compartment) when set for an extended period of time below the cold end of the temperature range for which the refrigerating appliance is designed.
- 2.** Effervescent drinks should not be stored in food freezer compartments or cabinets or in low-temperature compartments or cabinets because some products such as water ice should not be consumed too cold;
- 3.** Do not exceed the storage time(s) recommended by the food manufacturers for any kind of food and particularly for commercially quick-frozen food in food-freezer and frozen-food storage compartments or cabinets
- 4.** Prevent an undue rise in temperature of frozen food while defrosting the refrigerating appliance, such as wrapping the frozen food in several layers of newspaper.
- 5.** A rise in temperature of frozen food during manual defrosting, maintenance or cleaning can shorten the storage life

DISPOSAL



Refrigerant and cyclopentane foaming material used for the refrigerator are flammable. Therefore, when the refrigerator is scrapped, it shall be kept away from any fire source and be recovered by a special recovering company with corresponding qualification other than be disposed by combustion, so as to prevent damage to the environment or any other harm.



When the refrigerator is scrapped, disassemble the doors, and remove gasket of door and shelves; put the doors and shelves in a proper place, so as to prevent trapping of any child.

Correct Disposal of this product:



This marking indicates that this product should not be disposed with other household waste. To prevent possible harm to the environment or human health from uncontrolled waste disposal, recycle it responsibly to promote the sustainable reuse of material resources. To return your used device, please use the return and collection systems or contact the retailer where the product was purchased. They take this product in for environmental safe recycling.

2. PROPER USE OF REFRIGERATOR

2.1 PLACEMENT

- Before use, remove all packing materials, including bottom pads, foam pads and tapes inside of the refrigerator; tear off the protective film on the doors and the refrigerator body.

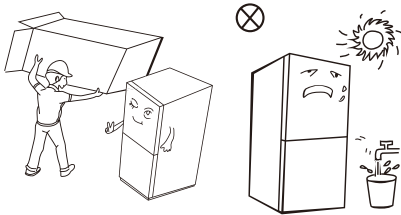

- Keep away from heat and avoid direct sunlight. Do not place the freezer in moist or wet places to prevent rust or reduction of the insulating effect.
- Do not spray or wash the refrigerator; do not put the refrigerator in moist places easy to be splashed with water so as not to affect the electrical insulation properties of the refrigerator.

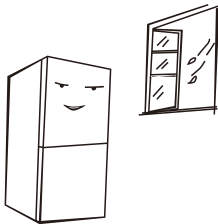

- The space on top of the refrigerator shall be greater than 10cm, and the refrigerator should be placed against a wall with a distance of more than 10cm to facilitate heat dissipation.

Spare enough space for convenient opening of the doors and drawers or statement by the distributor.

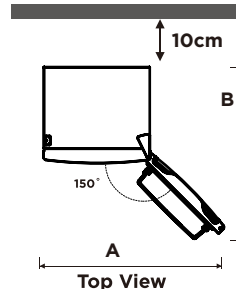
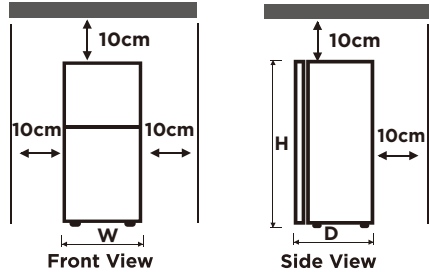

	HK124W
Width "w"	470
Depth "D"	511
Height "H"	1240
A	965
B	1038

(unit: mm)

The measurements in the above table may differ, depending on the measuring method.

NOTE:

This refrigerator needs to be installed independently and cannot be used as a built-in. Otherwise, it will cause problems such as failure to install into the cabinet, the performance and life of the product are reduced. And the manufacturer does not provide basic product warranty.

2.2 ENERGY SAVING TIPS

- The appliance should be located in the coolest area of the room, away from heat producing appliances or heating ducts, and out of the direct sunlight.
- Let hot foods cool to room temperature before placing in the appliance. Overloading the appliance forces the compressor to run longer. Foods that freeze too slowly may lose quality, or spoil.
- Be sure to wrap foods properly, and wipe containers dry before placing them in the appliance. This cuts down on frost build-up inside the appliance.
- Appliance storage bin should not be lined with aluminum foil, wax paper, or paper toweling. Liners interfere with cold air circulation, making the appliance less efficient.
- Organize and label food to reduce door openings and extended searches. Remove as many items as needed at one time, and close the door as soon as possible.

2.3 CHANGING THE LIGHT

- Any replacement or maintenance of the LED lamps is intended to be made by the manufacturer, its service agent or similar qualified person.

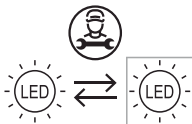

2.4 START TO USE

- Before initial start, keep the refrigerator still for two hours before connecting it to power supply.
- Before placing any fresh or frozen foods, the refrigerator should have run for 2 - 3 hours, or for above 4 hours in summer when the ambient temperature is high.

NOTE

This product is not recommended for use with sockets or main switch with the A/GFCI function, otherwise it may cause false tripping.

- 1. it's not pose a safety risk when tripped.**
- 2. If tripping persists, it is recommended to replace the sockets or main switch without A/GFCI function.**

2.5 NAMES OF COMPONENTS

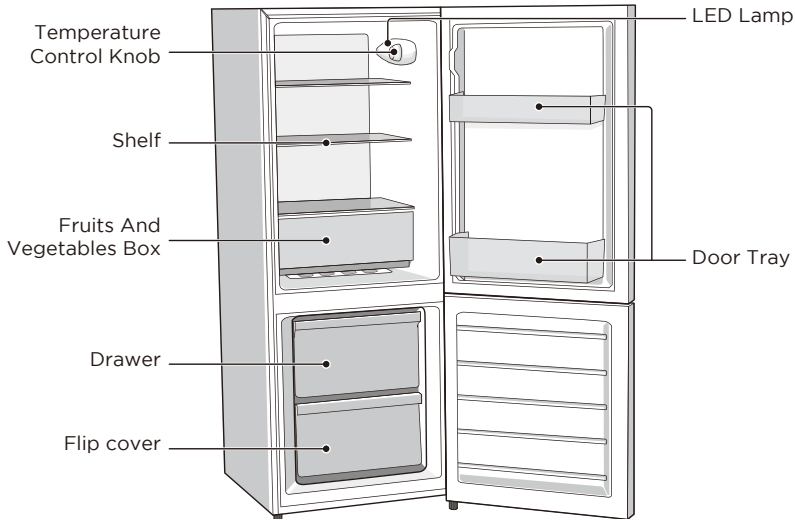

The picture above is only for reference. The actual configuration will depend on the physical product or statement by the distributor

Refrigerating chamber

- The Refrigerating Chamber is suitable for storage of a variety of fruits, vegetables, beverages and other food consumed in the short term, suggested storage time 3 days to 5 days.
- Cooking foods shall not be put in the refrigerating chamber until cooled to room temperature.
- Foods are recommended to be sealed up before putting into the refrigerator.
- The glass shelves can be adjusted up or down for a proper storage space and easy use.

Freezing chamber

- The low temperature freezing chamber may keep food fresh for a long time and it is mainly used to store frozen foods and making ice.
- The freezing chamber is suitable for storage of meat, fish, rice balls and other foods not to be consumed in short term.
- Chunks of meat are preferably to be divided into small pieces for quick freezing and easy access. Please be noted food shall be consumed within the shelf time.

NOTE

Storage of too much food during operation after the initial connection to power may adversely affect the freezing effect of the refrigerator. Foods stored shall not block the air outlet; or otherwise the freezing effect will also be adversely affected

2.6 FUNCTIONS

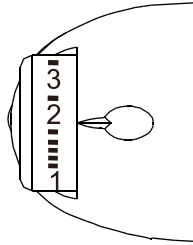

- Turn the temperature control knob to 3, the internal temperature of the refrigerator becomes lower.
- Turn the temperature control knob to 1, the internal temperature of the refrigerator becomes higher.
- The letter on the knob only represents the temperature level, but does not mean the specific temperature, the “0” means stop working.

NOTE

Please adjusting and using between “1”and”3”.





Above gear 3 will cause that the internal temperature of the refrigerator is too low, so it is not recommended for users.

NOTE

- **When storing food normally, please adjust the temperature setting between MAX and MIN.**
- **The coldest gear can quickly freeze food in a short period of time. If a large amount of food is frozen at one time, it is recommended to adjust the gear to the coldest gear 12 hours in advance before adding the food. After the food is quickly frozen, please adjust the gear back to the normal range.**
- **The temperature range for cooled food is generally 2-8°C, and the temperature range for frozen food is generally -12°C--26°C.**

The picture above is only for reference. The actual configuration will depend on the physical product or statement by the distributor

2.7 LEVELING DOOR

List of tools to be provided by the user	
	Cross screwdriver
	Putty knife/thin-blade screwdriver
	5/16" socket and ratche
	Masking tape

Parts to be used for door reverse			
SN	parts	Quantity	Notes
1	Upper hinge	1	Pre-installed on the refrigerator and to be used when changing the door
2	Upper hinge cover	1	
3	Hole cover	1	
4	Reft stopper	2	
5	Left stopper	2	In the attached plastic bag, take them out for use when door is reversed
6	Middle hinge	1	Pre-installed on the refrigerator and to be used when changing the door
7	Insert pin	2	
8	Right lower hinge	1	
9	Left lower hinge	1	In the attached plastic bag, take them out for use when door is reversed
10	Levelling feet	1	Pre-installed on the refrigerator and to be used when changing the door
11	Spacer	1	In the attached plastic bag, take them out for use when door is reversed

- Power off the refrigerator, and remove all objects from the door trays.
- Remove the hinge cover, then remove the upper hinge screws, upper hinge and hole cap on the other side.

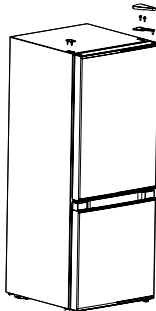

- Remove the refrigerating door, the middle hinge, the screw hole caps. Remove the screws and limit blocks fixed on the lower end cover of refrigeration.

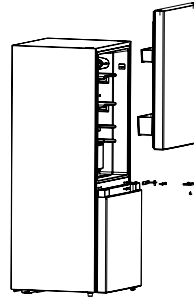

- Remove the freezer door, remove the bottom hinge and adjustable foot of the other side.
- Install the adjusting foot to the right side, take out 2 limit blocks from the plastic bag in the instruction manual and fix them to the left side of the lower end cover respectively with screws, and freeze the left side of the lower end cover. Remove the other side of the lower hinge from the instruction bag and install it on the left side.

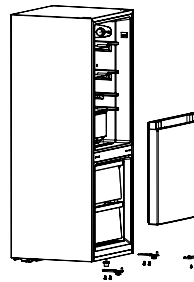

- Place the freezer door from top to bottom, take out the gasket from the plastic bag in the instructions and put it into the axle hole on the left side of the freezer door, as shown in the picture. Fix the center hinge with screws and install the studs.

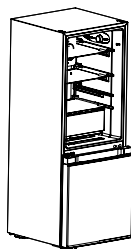

- Put the refrigerating door on the middle hinge, assemble the upper hinge on the other side, fix the hinge cover on the upper hinge and fix hole cap on the other side.

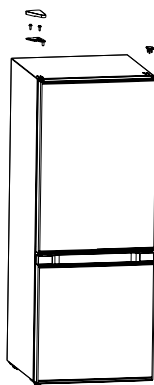

2.8 LEVELING FEET

1) Precautions before operation:

Before operation of accessories, it shall be ensured that the refrigerator is disconnected from power.

Before adjusting the leveling feet, precautions shall be taken to prevent any personal injury.

2) Schematic diagram of the leveling feet

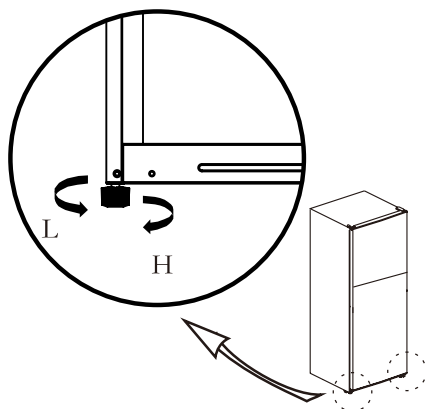

3) Adjusting procedures:

- Turn the feet clockwise to raise the refrigerator;
- Turn the feet counterclockwise to lower the refrigerator;
- Adjust the right and left feet based on the procedures above to a horizontal level.

NOTE

NOTE: The picture above is only for reference. The actual configuration will depend on the physical product or statement by the distributor.

IMPORTANT:

The picture above is only for reference. The actual configuration will depend on the physical product or statement by the distributor

3. MAINTENANCE OF REFRIGERATOR

3.1 OVERALL CLEANING

- Dusts behind the refrigerator and on the ground shall be timely cleaned to improve the cooling effect and energy saving.
- Check the door gasket regularly to make sure there are no debris. Clean the door gasket with a soft cloth dampened with soapy water or diluted detergent.
- The interior of the refrigerator should be cleaned regularly to avoid odor.
- Please turn off the power before cleaning interior, remove all foods, drinks ,shelves, drawers, etc.
- Use a soft cloth or sponge to clean the inside of the refrigerator, with two tablespoons of baking soda and a quart of warm water. Then rinse with water and wipe clean. After cleaning, open the door and let it dry naturally before turning on the power.
- For areas that are difficult to clean in the refrigerator (such as narrow sandwiches, gaps or corners), it is recommended to wipe them regularly with a soft rag, soft brush, etc. and when necessary, combined with some auxiliary tools (such as thin sticks) to ensure no contaminants or bacterials accumulation in these areas.
- Do not use soap, detergent, scrub powder, spray cleaner, etc., as these may cause odors in the interior of the refrigerator or contaminated food.
- Clean the bottle frame, shelves and drawers with a soft cloth dampened with soapy water or diluted detergent. Dry with a soft cloth or dry naturally.
- Wipe the outer surface of the refrigerator with a soft cloth dampened with soapy water, detergent, etc., and then wipe dry.
- Do not use hard brushes, clean steel balls, wire brushes, abrasives (such as toothpastes), organic solvents (such as alcohol, acetone, banana oil, etc.), boiling water, acid or alkaline items, which may damage the fridge surface and interior. Boiling water and organic solvents such as benzene may deform or damage plastic parts.
- Do not rinse directly with water or other liquids during cleaning to avoid short circuits or affect electrical insulation after immersion.



Please unplug the refrigerator for defrost and cleaning.

3.2 DEFROSTING

This product requires manual defrost.

- Power off the refrigerator.
- Remove the food from the refrigerator and place it properly to prevent food from melting.
- Clear the drain pipe (to use soft materials to prevent damage to the liner), Prepare the water containers for defrosting.(pay attention to clean the compressor compartment water draining tray,Avoding overflow to the ground).
- You can use the natural temperature for the natural defrost, you can also use the ice shovel to eliminate the frost (to use plastic or wooden ice shovel, for avoding damage to the liner or pipe)
- You can also use the appropriate amount of hot water to speed up the defrost, with a dry towel to dry the water after defrosting.
- After defrosting, put back the foods in cabinet , and power on the refrigerator.

3.3 OUT OF OPERATION

- Power failure: In case of power failure, even if it is in summer, foods inside the appliance can be kept for several hours; during the power failure, the times of door opening shall be reduced, and no more fresh food shall be put into the appliance.
- Long-time nonuse: The appliance shall be unplugged and then cleaned; then the doors are left open to prevent odor.

- Moving: Before the refrigerator is moved, take all objects inside out, fix the glass partitions, vegetable holder, freezing chamber drawers and etc. with tape, and tighten the leveling feet; close the doors and fix them with tape. During moving, the appliance shall not be laid upside down or horizontally, or be vibrated; the inclination during movement shall be no more than 45°.

IMPORTANT:

The appliance shall run continuously once it is started. Generally, the operation of the appliance shall not be interrupted;otherwise the service life may be impaired

3.4 CLEANING THE GLASS SHELF

- Remove the drawer on the glass shelf;
- Lift up the front of glass shelf(about 60°), and then pull out;
- Remove the glass shelf and clean as needed;
- The reverse operation is for installation of glass shelf.

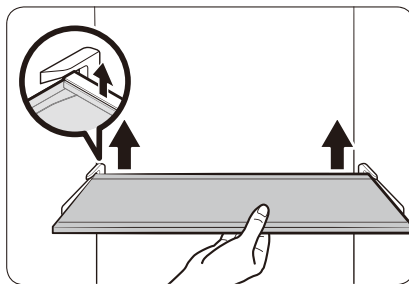

4. TROUBLE SHOOTING

The following simple issues can be handled by the user. Please call the after-sale service department if the issues are not solved.

Failed operation	<p>Check whether the appliance is connected to power or whether the plug is in well contact</p> <p>Check whether the voltage is too low</p> <p>Check whether there is a power failure or partial circuits have tripped</p>
Odor	<p>Odorous foods shall be tightly wrapped</p> <p>Check whether there is any rotten food</p> <p>Clean the inside of the refrigerator</p>
Long-time operation of the compressor	<p>Long operation of the refrigerator is normal in summer when the ambient temperature is high It is not suggestible having too much food in the appliance at the same time</p> <p>Food shall get cool before being put into the appliance</p> <p>The doors are opened too frequently</p>
Light fails to get lit	<p>Check whether the refrigerator is connected to power supply and whether the illuminating light is damaged</p> <p>Have the light replaced by a specialist</p>
Door can not be properly closed	<p>The door is stuck by food packages Too much food is placed</p> <p>The refrigerator is tilted.</p>
Loud noises	<p>Check whether the floor is level and whether the refrigerator is placed stably</p> <p>Check whether accessories are placed at proper locations</p>
Door seal fails to be tight	<p>Remove foreign matters on the door seal</p> <p>Heat the door seal and then cool it for restoration (or blow it with an electrical drier or use a hot towel for heating)</p>
Water pan overflows	<p>There is too much food in the chamber or food stored contains too much water,resulting in heavy defrosting</p> <p>The doors are not closed properly, resulting in frosting due to entry of air and increased water due to defrosting</p>
Hot housing	<p>Heat dissipation of the built-in condenser via the housing, which is normal</p> <p>When housing becomes hot due to high ambient temperature, storage of too much food or shutdown of the compressor is shut down, provide sound ventilation to facilitate heat dissipation</p>
Surface condensation	<p>Condensation on the exterior surface and door seals of the refrigerator is normal when the ambient humidity is too high. Just wipe the condensate with a clean towel.</p>
Abnormal noise	<p>Buzz: The compressor may produce buzzes during operation, and the buzzes are loud particularly upon start or stop. This is normal.</p> <p>Creak: Refrigerant flowing inside of the appliance may produce creak, which is normal.</p>

5. APPENDIX

Installation Instructions

For refrigerating appliances with climate class

Depending on the climate class, this refrigerating appliance is intended to be used at ambient temperature ranges as specified following table. The climate class can be found on the rating plate. The product may not operate properly at temperatures outside of the specified range.

You can find the climate class on the label inside your refrigerator.

Effective temperature range

The refrigerator is designed to operate normally in the temperature range specified by its class rating.

Class	Symbol	Ambient temperature range °C	
		IEC 62552 (ISO 15502)	ISO 8561
Extended temperate	SN	+ 10 to + 32	+ 10 to + 32
Temperate	N	+ 16 to + 32	+ 16 to + 32
Subtropical	ST	+ 16 to + 38	+ 18 to + 38
Tropical	T	+ 16 to + 43	+ 18 to + 43

NOTE

The cooling performance and power consumption of the refrigerator may be affected by the ambient temperature, the door-opening frequency, and the location of the refrigerator. We recommend adjusting the temperature settings as appropriate.

How to store for best preservation (applicable models only)

Cover foods to retain moisture and prevent them from picking up odors from other foods. A large pot of food like soup or stew should be divided into small portions and put in shallow containers before being refrigerated. A large cut of meat or whole poultry should be divided into smaller pieces or placed in shallow containers before being refrigerated.

Placement of Foods

Shelves	Shelves are adjustable to accommodate a variety of packages.
Specialized compartment (applicable models only)	Sealed crisper drawers provide an optimal storage environment for fruit and vegetables. Vegetables require higher humidity while fruit requires lower humidity. Crispers are equipped with control devices to control the humidity level. (*Depending on model and options) An adjustable temperature meat drawer maximizes the storage time of meats and cheeses.
Stored on the door	Don't store perishable foods in the door. Eggs should be stored in the carton on a shelf. The temperature of the storage bins in the door fluctuate more than the temperature in the cabinet. Keep the door closed as much as possible.
Freezer Compartment	You can store frozen food, make ice cubes and freeze fresh food in the freezer compartment.

NOTE

Freezer fresh, undamaged food only. Keep food which is to be frozen away from food which is already frozen. To prevent food from losing its flavour or drying out, place in airtight containers.

Refrigerator & Freezer Storage Chart

The freshness longevity depends on temperature and exposure to moisture. Since product dates aren't a guide for safe use of a product, consult this chart and follow these tips.

Milk products

Product	Refrigerator	Freezer
Milk	1 week	1 month
Butter	2 weeks	12 months
Ice cream	-	2-3 weeks
Natural cheese	1 month	4-6 months
Cream cheese	2 weeks	Not recommended
Yogurt	1 month	-

Meat

Product	Refrigerator	Freezer
Fresh roasts, steaks, chops	3-4 days	2-3 months
Fresh ground meat, stew meat	1-2 days	3-4 months
Bacon	7 days	1 month
Sausage, Raw from pork, beef, turkey	1-2 days	1-2 months

Poultry / Eggs

Product	Refrigerator	Freezer
Fresh poultry	2 days	6-8 months
Poultry salad	1 day	-
Eggs, Fresh in shell	2-4 weeks	Not recommended

Fish / Seafood

Product	Refrigerator	Freezer
Fresh fish	1-2 days	3-6 months
Cooked fish	3-4 days	1 month
Fish salad	1 day	Not recommended
Dried or pickled fish	3-4 weeks	-

Fruits

Product	Refrigerator	Freezer
Apples	1 month	-
Peaches	2-3 weeks	-
Pineapple	1 week	-
Other fresh fruit	3-5 days	9-12 months

Vegetables

Product	Refrigerator	Freezer
Asparagus	2-3 days	-
Broccoli, Brussels sprouts, green peas, mushrooms	3-5 days	-
Cabbage, cauliflower, celery, cucumbers, lettuce	1 week	-
Carrots, beets, radishes	2 weeks	-

SPECIAL FOR NEW EUROPEAN STANDARD

The ordered parts in the following table can be acquired from Service provider channel

Ordered part	Provided by	Minimum time required for Provision
Thermostats	Professional maintenance personnel	At least 7 years after the last model is launched on the market
Temperature sensors	Professional maintenance personnel	At least 7 years after the last model is launched on the market
Printed circuit boards	Professional maintenance personnel	At least 7 years after the last model is launched on the market
Light sources	Professional maintenance personnel	At least 7 years after the last model is launched on the market
Door handles	Professional repairers and final users	At least 7 years after the last model is launched on the market
Door hinges	Professional repairers and final users	At least 7 years after the last model is launched on the market
Trays	Professional repairers and final users	At least 7 years after the last model is launched on the market
Baskets	Professional repairers and final users	At least 7 years after the last model is launched on the market
Door gaskets	Professional repairers and final users	At least 10 years after the last model is launched on the market

Dear customer

1. If you want to return or replace the product, please contact the store where you buy.

(Remember to bring the purchase invoice)

2. If your product breaks down which needs to repair, please contact after-sales service provider.

NOTE

The model information in the product database, as well as the model identifier, can be obtained through a weblink scanned by a QR code, if any, on the energy efficiency label of the product.

WARRANTY

This product is guaranteed for 2 years from the date of original purchase. If the product fails within this period due to faulty materials or workmanship, it will be repaired, replaced or refunded at our discretion. Proof of purchase will be required.

This warranty applies only to:

- Product installed and used in accordance with the instructions contained in this manual.
- Product used for domestic purposes only.
- Product purchased in the UK and Ireland.

This warranty does not cover:

- Cosmetic damage.
- Normal wear and tear or consumable parts.
- Incorrect voltage supply or power surges.
- Customer misuse, modifications or adjustments.
- Products with unreadable or removed serial numbers.

Haden disclaims any liability for incidental or consequential loss or damages.

In the event of a problem:

- Please refer to the troubleshooting tips section within your user guide for help and guidance.
- If you are still unable to resolve the problem, please contact our technical support team for assistance.

When contacting Haden please provide:

- Product model number and serial number. Model & serial numbers can be found on the product rating label.
- Date of purchase.
- Complete description of the problem.

This information will help our team assist you more quickly.

Help Line: 01759 487 830
Opening Hours: Monday - Friday 9am – 5pm



**Sabichi Homewares Ltd.
Sabichi House,
5 Wadsworth Road, Perivale
Middlesex, UB6 7JD**

www.haden.com