

**iQ300, Washing machine, front loader, 8 kg, 1400 rpm
WM14NK09GB**



iSensonic Washing Machine with iQDrive for highly effective and efficient laundry care.

- ✓ speedPack L – Speed up your programmes, or wash in just 15 minutes.
- ✓ Best Energy Efficiency label A - Our most energy-efficient washing machine.
- ✓ LED simple touch display - easy to use and shows all relevant information clearly
- ✓ Outdoor – Gentle cleaning for water-repellent fabrics, seams and membranes.
- ✓ Efficient, quiet, and durable with guarantee - iQdrive with 10 year guarantee

Features

Technical Data

Energy Efficiency Class:A
 Weighted energy consumption in kWh per 100 washing cycles of eco 40-60 programme:46 kWh
 Maximum capacity in kg:8.0 kg
 The water consumption of the eco programme in liters per cycle: 47 l
 Duration of eco 40-60 programme in hours and mins at rated capacity: 3:33 h
 Spin-drying efficiency class of eco 40-60 programme: B
 Airborne acoustical noise emission class:A
 Airborne acoustical noise emissions : 71 dB(A) re 1 pW
 Design: Freestanding
 Height of removable worktop:0 mm
 Dimensions of the product: 848 x 598 x 590 mm
 Weight: 70.7 kg
 Connection Rating: 2300 W
 Fuse protection: 10 A
 Nominal power: 220-240 V
 Frequency: 50 Hz
 Length of electrical supply cord: 210.0 cm
 Door opening:Left
 Wheels: No
 EAN code:4242003933022
 Installation type: Freestanding



Optional accessories

- | | |
|----------|--|
| WX975600 | Floor securing component |
| WZ10131 | Extension for cold water inlet /Aquastop |
| WZWP20W | Platform with pull-out, washer, cubic |

iQ300, Washing machine, front loader, 8 kg, 1400 rpm WM14NK09GB

Features

Performance

- Energy Efficiency Class¹: A
- Energy² / Water³: 46 kWh / 47 litres
- Load capacity: 1 - 8 kg
- Programme duration⁴: 3:33 h:min
- Spin drying efficiency class: B
- Spin speed^{**}: 400 - 1400 rpm
- Noise level: 71 dB (A) re 1 pW
- Noise efficiency class: A

Programmes/functions

- Standard programmes: cottons, easy care, delicates, wool hand wash
- Special programmes: Dark Wash, Outdoor, shirts/blouses, mixed fabrics, rapid 15 minute quick wash, duvet, drum clean with reminder, wool/handwash, delicates/silk

Key features

- varioSpeed: Up to 65% reduced washing cycle ***
- Touch control buttons: prewash, Ready in, temperature selection, varioSpeed, start/pause with reload function, Water & Rinse Plus, spin speed selection

Additional features

- Reload Function: Stop the washing machine to add any forgotten items of laundry to the drum.
- Large display for programme progress indication, spin speed, remaining time, 24 hour end time delay and load recommendation.
- Drum volume: 65 litres
- Aqua Protection
- Fully electronic control dial for all wash and special programmes
- antiVibration Design - for more stability and quietness
- iQdrive with 10 year warranty
- iQdrive with 10 year warranty
- waterPerfect Plus: for efficient use of water even with small loads thanks to intelligent sensor technology.
- Foam detection system
- Out of balance load adjustment
- No
- End of cycle buzzer
- Electronic child safety package
- Divider for Liquid Detergent
- Large grey, white door with 171° opening
- Metal door catch
- Magnet door lock

Technical Information

- Slide-under installation
- Dimensions (H x W): 84.8 cm x 59.8 cm
- Appliance depth: 59.0 cm
- Appliance depth incl. door: 63.2 cm
- Appliance depth with open door: 106.3 cm

¹ Scale of Energy Efficiency Classes from A to G

² Energy consumption in kWh per 100 cycles (in programme Eco 40-60)

³ Weighted water consumption in litres per cycle (in programme Eco 40-60)

⁴ Duration of Eco 40-60 programme

** Values are rounded.

*** Comparison between the program duration of Easy-care 40°C and the program duration of Easy-care 40°C + activated varioSpeed option

**iQ300, Washing machine, front loader, 8 kg, 1400 rpm
WM14NK09GB**

Dimensioned drawings

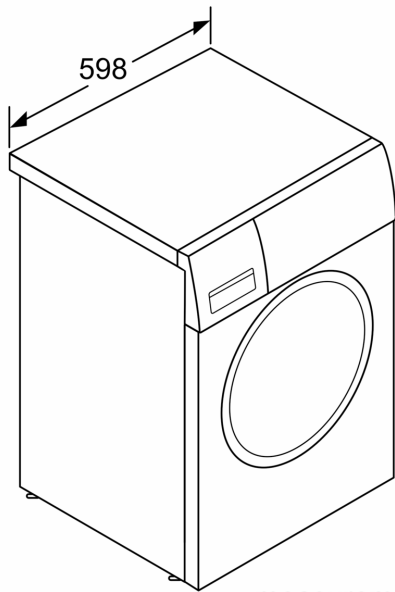

measurements in mm

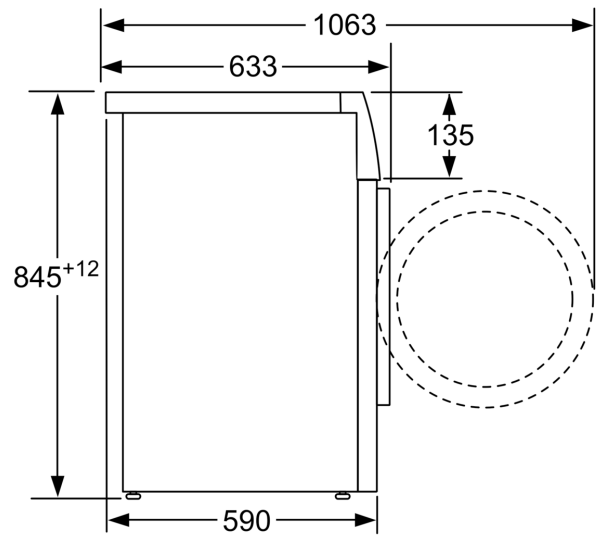

measurements in mm