

# DUSF400S



Category	Double under-counter
Product Family	Oven
Power supply	Electric
Heat source	Electric
Heat source second cavity	Electric
Cooking method	Thermo-ventilated
Cooking Method Secondary Oven	Static
EAN code	8017709272654



## Aesthetics

Aesthetics	Cucina	Serigraphy colour	Grey
Colour	Silver	Serigraphy type	Symbols
Design	Flat	Door	Full glass
Component finish	Stainless steel	Handle	Squared Selection
Material	Stainless steel	Handle Colour	Steel effect
Type of steel	Brushed	Logo	Silk screen
Glass Type	Stopsol		

## Programs / Functions

No. of cooking functions 4

Traditional cooking functions



Ciculaire



ECO



Large grill



Fan grill (large)

## Programs / Functions Auxiliary Oven

No. of functions Secondary oven 4

## Traditional cooking functions, cavity 2



Static



ECO



Small grill



Large grill

## Controls



<b>Display name</b>	DigiScreen	<b>Control knobs</b>	Cucina restyling
<b>Display technology</b>	LED	<b>Controls colour</b>	Steel effect
<b>Control setting</b>	Knobs & touch buttons	<b>Buttons colour</b>	Silver
<b>No. of controls</b>	4		

## Options



<b>Time-setting options</b>	Delay start and automatic end cooking	<b>Timer</b>	1
<b>Minute minder</b>	Yes	<b>Rapid pre-heating</b>	Yes

## Options Auxiliary Oven

<b>Time-setting options</b>	No delay options
-----------------------------	------------------

## Technical Features



<b>Minimum Temperature</b>	50 °C	<b>Door</b>	Temperate door
<b>Maximum temperature</b>	250 °C	<b>Removable door</b>	Yes
<b>Shelf positions</b>	4	<b>Full glass inner door</b>	Yes
<b>Shelves type</b>	Metal racks	<b>Removable inner door</b>	Yes
<b>No. of lights</b>	1	<b>Total no. of door glasses</b>	3
<b>Light type</b>	Halogen	<b>Safety Thermostat</b>	Yes
<b>User-replaceable light</b>	Yes	<b>Cooling system</b>	Tangential
<b>Light power</b>	40 W	<b>Cooling duct</b>	Single
<b>Grill element - power</b>	1800 W	<b>Speed Reduction</b>	Yes
<b>Circular heating element - Power</b>	2700 W	<b>Cooling System</b>	
<b>Heating suspended when door is opened</b>	Yes	<b>Usable cavity space dimensions (HxWxD)</b>	316x460x412 mm
<b>Door opening type</b>	Standard opening	<b>Temperature control</b>	Electro-mechanical
		<b>Cavity material</b>	Easy clean enamel

## Second Oven Technical Features



<b>Minimum Temperature</b>	80 °C	<b>Grill element - power</b>	1700 W
<b>Maximum temperature</b>	250 °C	<b>Large grill - Power</b>	2700 W
<b>Shelf positions</b>	2	<b>Removable door</b>	Yes
<b>Tilting grill</b>	Yes	<b>Full glass inner door</b>	Yes
<b>No. of lights</b>	1	<b>Removable inner door</b>	Yes
<b>Light type</b>	Halogen	<b>No. of total door glasses</b>	3
<b>Light power</b>	40 W	<b>No. of thermoreflecting door glasses</b>	1
<b>Bottom heating element power</b>	1200 W	<b>Usable cavity space dimensions (HxWxD)</b>	169x440x443 mm
<b>Upper heating element - Power</b>	1000 W		

## Performance / Energy Label



<b>Energy efficiency class</b>	A	<b>Number of cavities</b>	2
<b>Net volume of the cavity</b>	61 litres	<b>Energy efficiency index</b>	95.1 %
<b>Energy consumption in forced air convection</b>	2.77 MJ	<b>Energy Efficiency Index, second cavity</b>	120 %
<b>Energy consumption per cycle in fan-forced convection</b>	0.77 KWh		

## Performance /Energy Label - Second Cavity



<b>Energy efficiency class, second cavity</b>	B	<b>Net volume of the second cavity</b>	35 litres
<b>Energy efficiency class, second cavity</b>	B	<b>Gross volume of second cavity</b>	41 l
<b>Energy consumption per cycle in conventional mode, second cavity</b>	0.84 KWh	<b>Cavity type EN 50304 second oven</b>	small
<b>Consumo di energia per ciclo in convezione naturale, seconda cavità</b>	3.02 MJ		

## Accessories Included

<b>Chrome shelf</b>	2	<b>Extra deep enamelled tray (40mm)</b>	2
<b>Grill mesh</b>	2		

## Electrical Connection

<b>Voltage</b>	220-240 V	<b>Voltage 2 (V)</b>	380-415 V
<b>Current</b>	21 A		

Frequency (Hz)

50/60 Hz

Nominal power (W)

4800 W

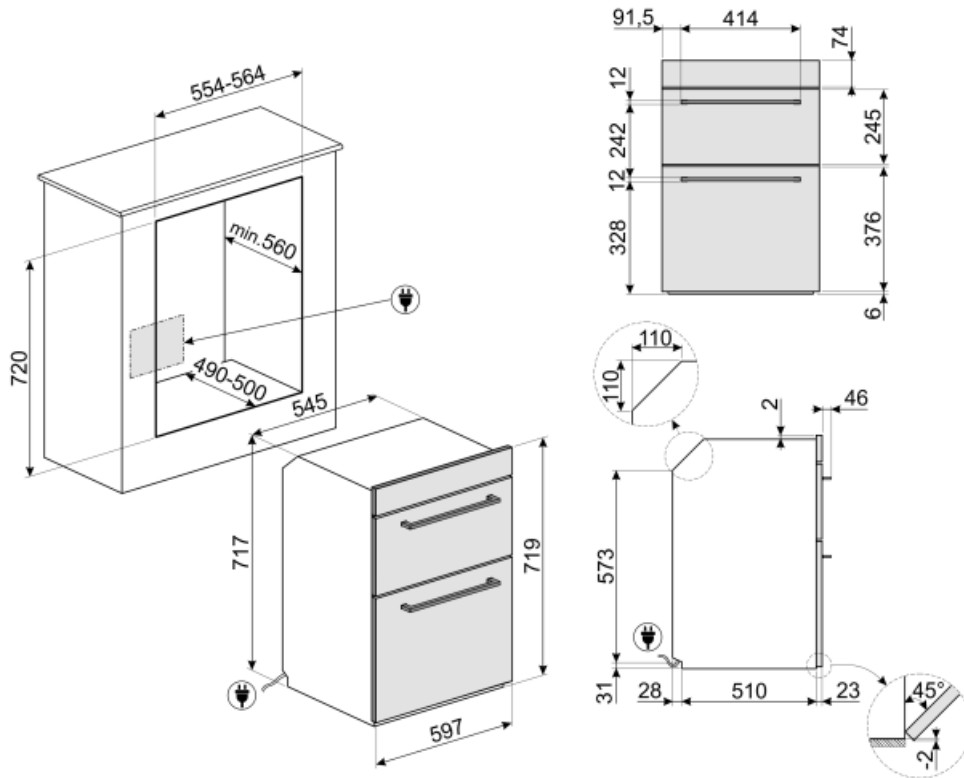

---

## Not included accessories

---

### GTP

\*\*Partially extractable telescopic guides (1 level)\*\* Extraction: 300 mm Material: Stainless steel AISI 430 polished



### GTT

\*\*Totally extractable telescopic guides (1 level)\*\* Extraction: 433 mm Material: Stainless steel AISI 430 polished























### GT1P-2

Partially extractable telescopic guides (1 level) for ovens with metal frames. Length: 355.5 mm, extraction: 285 mm. Material: Stainless steel AISI 430 polished.



## Symbols glossary

- A** A: Product drying performance, measured from A+++ to D / G depending on the product family
-  Air cooling system: to ensure a safe surface temperatures.
-  Electric
-  Upper and lower element only: a traditional cooking method best suited for single items located in the centre of the oven. the top pf the oven will always be hottest. Ideal for roast, fruit cakes, bread etc.
-  ECO: The combination of the grill, fan and lower element is particularly suitable for cooking small quantities of food.
-  Grill element: Using of grill gives excellent results when cooking meat of medium and small portions, especially when combined with a rotisserie (where possible). Also ideal for cooking sausages and bacon.
-  Fan with grill element: The fan reduces the fierce heat from the grill, providing an excellent method of grilling various foods, chops, steaks, sausages etc. giving even browning and heat distribution, without drying out the food. The top two levels recommended for use, and the lower part of the oven can be used to keep items warm at the same time, an excellent facility when cooking a grilled breakfast. Half grill (centre portion only) is ideal for small quantities of food.
-  The inner door glass: can be removed with a few quick movements for cleaning.
-  Rapid preheat: The rapid preheat function can be used to reach the selected temperature in just a few minutes.
-  The oven cavity has 4 different cooking levels.
-  The capacity indicates the amount of usable space in the oven cavity in litres.
- B** B: Product energy rating, measured from A+++ to D / G depending on the product family.
-  Triple glazed doors: Number of glazed doors.
-  Enamel interior: The enamel interior of all Smeg ovens have a special antacid lining which helps keep the interior clean by reducing the amount of cooking grease adhering to it.
-  Circulaire: The combination of the fan and circular element around it gives a hot air cooking method. This provides many benefits including no preheat if cook time is more than 20 minutes, no flavour transfer when cooking different foods at the same time, less energy, and shorter cook times. Good for all types of food.
-  ECO: The combination of the grill, fan and lower element is particularly suitable for cooking small quantities of food.
-  Half grill: For rapid cooking and browning of foods. Best results can be obtained by using the top shelf for small items, the lower shelves for larger ones, such as chops or sausages. For half grill heat is generated only at the centre of the element, so is ideal for smaller quantities.
-  All glass inner door: All glass inner door, a single flat surface which is simple to keep clean.
-  Side lights: Two opposing side lights increase visibility inside the oven.
-  The oven cavity has 2 different cooking levels.
-  Tilting grill: the tilting grill can be easily unhooked to move the heating element and clean the roof of the appliance in one simple step.
-  The capacity indicates the amount of usable space in the oven cavity in litres.



The capacity indicates the amount of usable space in the oven cavity in litres.



...

## Benefit

---

**Rapid pre-heating**

Pre-riscaldamento rapido